

# International Journal of Physical Sciences

Volume 11 Number 17 16 September , 2016

ISSN 1992-1950



*Academic  
Journals*

## ABOUT IJPS

The **International Journal of Physical Sciences (IJPS)** is published weekly (one volume per year) by Academic Journals.

**International Journal of Physical Sciences (IJPS)** is an open access journal that publishes high-quality solicited and unsolicited articles, in English, in all Physics and chemistry including artificial intelligence, neural processing, nuclear and particle physics, geophysics, physics in medicine and biology, plasma physics, semiconductor science and technology, wireless and optical communications, materials science, energy and fuels, environmental science and technology, combinatorial chemistry, natural products, molecular therapeutics, geochemistry, cement and concrete research, metallurgy, crystallography and computer-aided materials design. All articles published in IJPS are peer-reviewed.

### Contact Us

**Editorial Office:** [ijps@academicjournals.org](mailto:ijps@academicjournals.org)

**Help Desk:** [helpdesk@academicjournals.org](mailto:helpdesk@academicjournals.org)

**Website:** <http://www.academicjournals.org/journal/IJPS>

**Submit manuscript online** <http://ms.academicjournals.me/>

## Editors

### **Prof. Sanjay Misra**

*Department of Computer Engineering, School of Information and Communication Technology  
Federal University of Technology, Minna,  
Nigeria.*

### **Prof. Songjun Li**

*School of Materials Science and Engineering,  
Jiangsu University,  
Zhenjiang,  
China*

### **Dr. G. Suresh Kumar**

*Senior Scientist and Head Biophysical Chemistry  
Division Indian Institute of Chemical Biology  
(IICB)(CSIR, Govt. of India),  
Kolkata 700 032,  
INDIA.*

### **Dr. Remi Adewumi Oluoyinka**

*Senior Lecturer,  
School of Computer Science  
Westville Campus  
University of KwaZulu-Natal  
Private Bag X54001  
Durban 4000  
South Africa.*

### **Prof. Hyo Choi**

*Graduate School  
Gangneung-Wonju National University  
Gangneung,  
Gangwondo 210-702, Korea*

### **Prof. Kui Yu Zhang**

*Laboratoire de Microscopies et d'Etude de  
Nanostructures (LMEN)  
Département de Physique, Université de Reims,  
B.P. 1039. 51687,  
Reims cedex,  
France.*

### **Prof. R. Vittal**

*Research Professor,  
Department of Chemistry and Molecular  
Engineering  
Korea University, Seoul 136-701,  
Korea.*

### **Prof Mohamed Bououdina**

*Director of the Nanotechnology Centre  
University of Bahrain  
PO Box 32038,  
Kingdom of Bahrain*

### **Prof. Geoffrey Mitchell**

*School of Mathematics,  
Meteorology and Physics  
Centre for Advanced Microscopy  
University of Reading Whiteknights,  
Reading RG6 6AF  
United Kingdom.*

### **Prof. Xiao-Li Yang**

*School of Civil Engineering,  
Central South University,  
Hunan 410075,  
China*

### **Dr. Sushil Kumar**

*Geophysics Group,  
Wadia Institute of Himalayan Geology,  
P.B. No. 74 Dehra Dun - 248001(UC)  
India.*

### **Prof. Suleyman KORKUT**

*Duzce University  
Faculty of Forestry  
Department of Forest Industrial Engineering  
Beciyorukler Campus 81620  
Duzce-Turkey*

### **Prof. Nazmul Islam**

*Department of Basic Sciences &  
Humanities/Chemistry,  
Techno Global-Balurghat, Mangalpur, Near District  
Jail P.O: Beltalpark, P.S: Balurghat, Dist.: South  
Dinajpur,  
Pin: 733103,India.*

### **Prof. Dr. Ismail Musirin**

*Centre for Electrical Power Engineering Studies  
(CEPES), Faculty of Electrical Engineering, Universiti  
Teknologi Mara,  
40450 Shah Alam,  
Selangor, Malaysia*

### **Prof. Mohamed A. Amr**

*Nuclear Physic Department, Atomic Energy Authority  
Cairo 13759,  
Egypt.*

### **Dr. Armin Shams**

*Artificial Intelligence Group,  
Computer Science Department,  
The University of Manchester.*

## Editorial Board

**Prof. Salah M. El-Sayed**

*Mathematics. Department of Scientific Computing,  
Faculty of Computers and Informatics,  
Benha University. Benha ,  
Egypt.*

**Dr. Rowdra Ghatak**

*Associate Professor  
Electronics and Communication Engineering Dept.,  
National Institute of Technology Durgapur  
Durgapur West Bengal*

**Prof. Fong-Gong Wu**

*College of Planning and Design, National Cheng Kung  
University  
Taiwan*

**Dr. Abha Mishra.**

*Senior Research Specialist & Affiliated Faculty.  
Thailand*

**Dr. Madad Khan**

*Head  
Department of Mathematics  
COMSATS University of Science and Technology  
Abbottabad, Pakistan*

**Prof. Yuan-Shyi Peter Chiu**

*Department of Industrial Engineering & Management  
Chaoyang University of Technology  
Taichung, Taiwan*

**Dr. M. R. Pahlavani,**

*Head, Department of Nuclear physics,  
Mazandaran University,  
Babolsar-Iran*

**Dr. Subir Das,**

*Department of Applied Mathematics,  
Institute of Technology, Banaras Hindu University,  
Varanasi*

**Dr. Anna Oleksy**

*Department of Chemistry  
University of Gothenburg  
Gothenburg,  
Sweden*

**Prof. Gin-Rong Liu,**

*Center for Space and Remote Sensing Research  
National Central University, Chung-Li,  
Taiwan 32001*

**Prof. Mohammed H. T. Qari**

*Department of Structural geology and remote sensing  
Faculty of Earth Sciences  
King Abdulaziz UniversityJeddah,  
Saudi Arabia*

**Dr. Jyhwen Wang,**

*Department of Engineering Technology and Industrial  
Distribution  
Department of Mechanical Engineering  
Texas A&M University  
College Station,*

**Prof. N. V. Sastry**

*Department of Chemistry  
Sardar Patel University  
Vallabh Vidyanagar  
Gujarat, India*

**Dr. Edilson Fereda**

*Graduate Program on Knowledge Management and IT,  
Catholic University of Brasilia,  
Brazil*

**Dr. F. H. Chang**

*Department of Leisure, Recreation and Tourism  
Management,  
Tzu Hui Institute of Technology, Pingtung 926,  
Taiwan (R.O.C.)*

**Prof. Annapurna P.Patil,**

*Department of Computer Science and Engineering,  
M.S. Ramaiah Institute of Technology, Bangalore-54,  
India.*

**Dr. Ricardo Martinho**

*Department of Informatics Engineering, School of  
Technology and Management, Polytechnic Institute of  
Leiria, Rua General Norton de Matos, Apartado 4133, 2411-  
901 Leiria,  
Portugal.*

**Dr Driss Miloud**

*University of mascara / Algeria  
Laboratory of Sciences and Technology of Water  
Faculty of Sciences and the Technology  
Department of Science and Technology  
Algeria*

**Prof. Bidyut Saha,**

*Chemistry Department, Burdwan University, WB,  
India*

**ARTICLES**

**Characterisation of mortars from the Ottoman period in Algiers (Algeria) through their physical and chemical properties** 217

Naima Abderrahim Mahindad and Messaoud Hamiane

**Development of a real time blood pressure, temperature measurement and reporting system for inpatients** 225

J. O. Egwaile, O. I. Omoifo, O. O. Odia and O. Okosun

*Full Length Research Paper*

# Characterisation of mortars from the Ottoman period in Algiers (Algeria) through their physical and chemical properties

Naima Abderrahim Mahindad\* and Messaoud Hamiane

<sup>1</sup>Research Unit Materials, Processes and Environment (Ex LMMC), Department of Materials Engineering, Faculties of Engineering, University of M'Hamed Bougarra, Boumerdes, Algeria.

Received 8 May, 2016; Accepted 22 August, 2016

In traditional and historical Algerian architecture, one can find a series of mortars that were used for grouting and coating masonry. Although Algeria has a very rich heritage park, our interest mainly focuses on the mortars used in buildings from the Ottoman period, in Algiers and in particular, the mortars of the Citadel of Algiers, the Casbah and villa Mahieddine. This study allows us to determine the physical properties of a selection of mortars and identify their chemical and mineralogical composition. The chemical and mineralogical analyses showed that the studied mortars of the Ottoman period in Algiers contain raw materials in their composition, namely sand, lime, crushed brick and a few additions, such as natural adjuvant. These mortars are made according to specific proportions of binder (lime) and aggregates (sand). For jointing mortars, the proportion is one-part lime to one and a half to two parts sand (1 to 1.5 - 2), whereas for finishing mortars, it is one-part lime for two to three parts sand (1 to 2-3). The physical characteristics show significant porosity and absorption percentages for most of the mortar samples, with exception to MJ4 jointing mortar samples, taken from Villa Mahieddine and MC1 coating mortar samples, taken from the Powder House and Villa Mahieddine, where the percentages did not exceed 15% of water absorption and 27% porosity, respectively. Furthermore, the chemical analysis of the samples showed increased levels of the following oxides SiO<sub>2</sub>, Al<sub>2</sub>O<sub>3</sub> and Fe<sub>2</sub>O<sub>3</sub>, which confirm the hydraulic nature of the mortars.

**Key words:** Algiers, characterisation, chemical and mineralogical composition, lime mortars, physical properties.

## INTRODUCTION

Knowing the characteristics of materials, is an important source of information for understanding the historical and archaeological evolution of mortars, and towards finding a mortar with the characteristics similar to old mortar,

which can then be used in the restoration of historical monuments.

The issue concerning the preparation of mortars for restoration purposes has become increasingly important

\*Corresponding author. Email: mahindadnaima@gmail.com Tel: 00213 555-025-627.

over the last decade. Mortars intended for the restoration of historic buildings must be compatible with the characteristics of the materials onto which they are to be applied or those that they are intended to replace (Rota Rossi, 1986). It is important that the mortar used during restoration and/or reconstruction operations, has the same morphological and physical characteristics, so that the new mortar does not differ too much from the old one (Ashurst, 1983).

Old mortar, in particular "Roman concrete" is the mortar of reference that has been in use since ancient times until today (Mallinowski, 1982). It has been used for the conservation of heritage objects (Büttner and Prigen, 2007). This mortar uses lime as a binding agent and is characterized for its great plasticity (Kuruğöl and Güleç, 2015).

In recent decades, research on masonry binders has essentially focused on the characterisation of the materials used in historic buildings (Palazzo-Bertholon, 1998; Coutelas, 2003; Binici et al., 2010). This new line of research opened a sphere towards new knowledge and perception of materials, through a scientific and analytical approach.

In the case of Algeria, studies relating to lime mortar are extremely rare and cover only a portion of its historical and archaeological heritage: Mortars of the Ottoman period in Algeria were studied through an unpublished literature exploited in the works of Chergui (2007) and that of Foufa (2010), and which consist of the Ottoman period archives. This first-hand documentation enables us to identify the different materials used at the time, as well as the construction techniques and their implementation, which reveals to us all of the local knowledge and mastery of the builders of that time. These studies were supported by works undertaken on the characterisation of mortars, which tell us about the composition of the same and their evolution (Boukhenouf, 2006; Belaidi, 2011, Ait ouakli, 2010). In addition to recent works on mortars of the Ottoman period in Algiers, proposing mortar preparations in order to find the compositions that are a closest match to old mortars and are thus compatible with them (Hamiane et al., 2010).

The mortar could be used for several purposes, such as, filling, grouting or coating. Whatever its use, the base components are the same: These mortars consist of sand and lime, to which have been added other components, such as the broken tiles or crushed bricks and in some cases, broken stone (Chergui, 2007). Other historic sources show evidence that the mortar of the Ottoman period consisted of lime and red clay or red sand, which were more or less clay-like (Lespès, 1930; Rozet, 1830).

The aim of this study is to characterise of ancient lime based mortars, used in previously selected Ottoman constructions and to identify their chemical and mineralogical composition, as well as its production techniques. The results obtained are compared to various historical studies.

In view of the diversity of Ottoman buildings, as regards their use and geographical location, we have limited our research to the most representative buildings, as regards their function and geographic location, in order to target a more comprehensive sampling of the mortars used during this period. The buildings selected as part of this study are:

1) The Citadel of Algiers: it is the pillar of Ottoman power, which consists of various structures, such as a palace and the mosque of Dey, Beys Palace, the Summer Pavilion, Hammam of Dey, the Janissaries quarter, the Skifa [a monumental door], pillboxes (The casemates) and the powder house. All of the above were built between the sixteenth and eighteenth centuries. Within this palatial complex, we have chosen two buildings from these samples, the powder house and the Casemates (The pillboxes). The two buildings show some deterioration in their masonry and in particular, in the coatings.

2) The Casbah of Algiers: The Medina, which constitutes the Ottoman city, contains most of the houses and dwellings of that time. These houses were built between the sixteenth and eighteenth centuries. Samples mortars studied of the Casbah of Algiers were taken from one of its houses. Most of the latter are in an advanced state of degradation. Their masonry has been considerably damaged.

3) Villa Mahieddine: This is a Fahs house (a house in the countryside). This villa was mostly used during the summer; it was built between the sixteenth and seventeenth century. It is a building that is in a better state of conservation than the other buildings and it shows very few signs of deterioration in the masonry and coatings. All samples studied are located in Figure 1.

## METHODOLOGY

### Materials

Mortar can have series of uses, such as jointing mortars for masonry, finishing mortar, coating and waterproofing for the terrace. In this study, we chose eight (08) samples of grouting and coating, found at the above listed sites. These mortars show the visual changes as regards their colours and textures.

### Jointing mortars

All samples of jointing mortars studied are presented in Figure 2.

a) The Citadel of Algiers: We have chosen two samples of jointing mortar:

i) The powder house (MJ1): Is a yellowish mortar (yellow beige), with a large quantity of scattered lime particles of a more or less significant size. It also contains grains of gravel, but in minute quantities. When handled, this is a brittle material, but which has eroded, the resulting particles of which have a heterogeneous particle size (Figure 2a).



**Figure 1.** Location of samples. a/b: Site of samples MJ1 and MC1: Powder keg; c/d: Site of samples MJ2 and MC2: Casemates; e/f: Site of samples MJ3 and MC3: Casbah of Algiers; g/h: Site of samples MJ4 and MC4: Villa Mahieddine.

ii) The Casemates (The pillboxes) (MJ2): This is an orange-coloured mortar, highly compact in appearance but which crumbles to the touch. Eroded, it consists of very fine red sand particles and dirt and shows the presence of whitish traces of lime in a very reduced amount, however the other components are not noticeable (Figure 2b).

b) The Casbah (MJ3): This is an orange coloured mortar, highly compact in appearance but brittle to the touch. Eroded, it consists

of very fine sand particles and dirt and shows the presence of whitish lime particles of lime of various sizes. With a naked eye, one can also easily see a given number of pores and grains of a larger grain size in a reddish-brown colour (Figure 2c).

c) The villa Mahieddine (MJ4): This is a bright orange coloured mortar, very compact in appearance but brittle to the touch. It has some dark spots (in very reduced quantities) and small-sized lime grains. Eroded, it consists of very fine particles of sand and clay (Figure 2d).



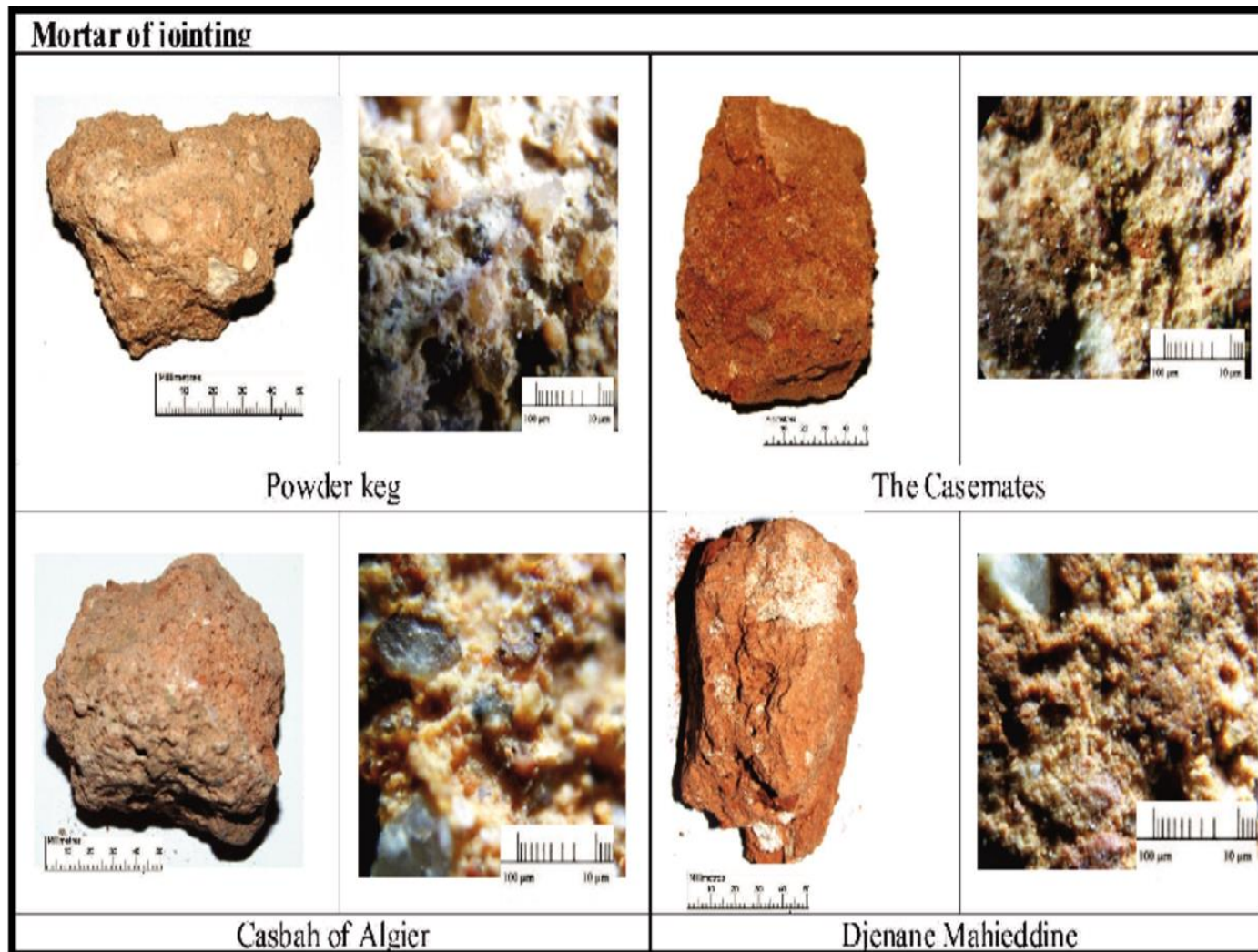

**Figure 2.** Observation of different samples of jointing mortar: The various samples present differences compared to their texture and their colors.

### Coating mortar

All samples of coating mortars studied are presented in Figure 3.

a) The Citadel of Algiers: We have selected two samples:

i) The powder house (MC1): The colour of this mortar is very clear. It is pinky-orange coloured, dotted with some very sparse brown spots and some large quantities of more or less big lime grains. This material is brittle to the touch and to the naked eye, it has a series of pores (Figure 3a).

ii) The Casemates (The pillboxes) (MC2): It is a very light pink coloured mortar, almost whitish, mottled with brown. It is dotted with very small quantities of lime particles. It is compact and has very few pores to the naked eye (Figure 3b).

b) The Casbah of Algiers (MC3): The coating mortar has a very nuanced colour, which ranges from yellow, pink and in some places whitish, which suggests a variety of components. This mortar is dotted with brownish red spots and large quantities of more or less

big lime grains. This material is brittle to the touch and to the naked eye, it has a series of pores. Eroded, it has different sized grains and even rubble (Figure 3c).

c) Villa Mahieddine (MC4): It is a reddish pink colour dotted with large quantities of brown spots of various sizes and some more or less big lime grains. It is very brittle to the touch and has a given number of pores that are visible to the naked eye (Figure 3d).

### Methods

Here, we chose the complementary analysis techniques, in order to carry out the chemical and mineralogical characterisation of the collected mortar samples. The advantages of this procedure are that the different results directly provide us a great deal of information. By combining the results of physical, mineralogical and chemical analysis, we have been able to identify the elements that compose them and check the first findings, giving us a better insight to the materials.

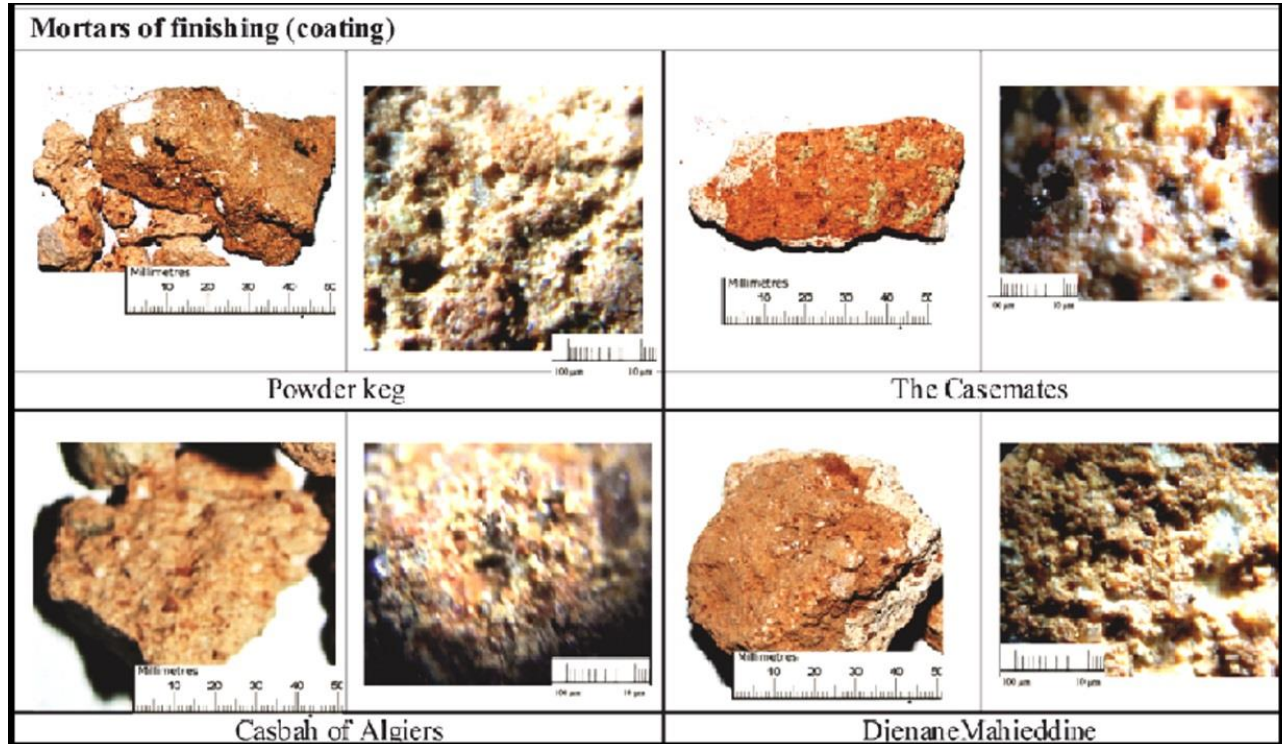

Figure 3. Observation of different samples of coating mortars.

### Physical analysis

Physical analysis enables us to identify the specific and apparent densities, as well as the percentage (%) of humidity, porosity and water absorption, according to French standards NF P18-558; NF P94-050; NF P18 554.

Determining the concentration of free lime (CaO) is done via the sucrose method, according to NF EN 459-2. Determining the concentration of free lime (CaO) is based on dissolving the sample in demineralised Water, which is then titrated with hydrochloric acid (HCl), diluted to 5%, and using phenolphthalein as indicator, hence, we can quantify the amount of free lime (CaO) expressed as a percentage.

### Mineralogical analysis

Its purpose is to identify minerals and their dosage for a quantitative estimate. This study was conducted using X-ray diffraction.

### Chemical analysis

The chemical composition of Ottoman mortars was determined by X-ray fluorescence, using the principle of standard NF P 15-467. The loss on ignition is determined at 1000 °C, under the provisions of standard EN 1744-1.

Historical studies pertaining to the Ottoman period refer to the possibility of using natural hydraulic lime in the composition of some mortars, hence the importance of calculating the hydraulic index, in order to verify this hypothesis.

The hydraulic index (HI) is calculated using Equation (1) (Boynton, 1980).

$$HI = \frac{Al_2O_3\% + Fe_2O_3\% + SiO_2\%}{CaO\% + MgO\%} \quad (1)$$

## RESULTS

### Physical properties

The results obtained from the physical analysis, are summarised in Table 1. They show that for jointing mortars, the highest value of apparent density is 1.67 g/cm<sup>3</sup> and the corresponding value of the specific density is 2.13 g/cm<sup>3</sup>. The value of the gap between the two densities is 0.46 g/cm<sup>3</sup>.

The highest value of apparent density, for coating mortars is 1.87 g/cm<sup>3</sup> and the higher value of their specific density is 2.54 g/cm<sup>3</sup>. The gap between the two values of densities is 0.67 g/cm<sup>3</sup>.

The sample of jointing mortar MJ4, has a lower percentage of water absorption (12.75%) and porosity (21.59%), than the MJ1 sample, which has a higher percentage of water absorption (20.18%) and porosity (31.89%). Likewise, of the coating mortars, sample MC4, has the lowest percentage of water absorption (13.53%) and a porosity (24.36%), while sample MC2 has the highest percentage of water absorption (18.84%) and porosity (28.84%).

The existence of free lime can be found on all samples, with rates varying from 2.21% to 3.36% for mortars. The

**Table 1.** Physical properties of mortars.

| Samples | Apparent density<br>$P_{\text{apparent}} \text{ (g/cm}^3\text{)}$ | Specific density<br>$\rho_{\text{specific}} \text{ (g/cm}^3\text{)}$ | Porosity<br>Pt (%) | Absorption<br>of water Ab (%) | Humidity<br>H (%) | Free lime<br>CaO (%) | pH (%) |
|---------|---|--|--------------------|-------------------------------|-------------------|----------------------|--------|
| MJ1     | 1.58  | 2.32   | 31.89              | 20.18                         | 1.20              | 2.24                 | 9.42   |
| MJ2     | 1.63  | 2.10   | 32.08              | 19.68                         | 9.70              | 2.15                 | 9.91   |
| MJ3     | 1.42  | 1.96   | 27.55              | 19.40                         | 1.08              | 2.21                 | 9.83   |
| MJ4     | 1.67  | 2.13   | 21.59              | 12.75                         | 7.05              | 3.36                 | 9.85   |
| MC1     | 1.87  | 2.54   | 26.37              | 14.10                         | 1.99              | 4.48                 | 9.95   |
| MC2     | 1.53  | 2.15   | 28.84              | 18.84                         | 2.01              | 5.60                 | 9.20   |
| MC3     | 1.47  | 1.98   | 27.75              | 17.51                         | 6.21              | 1.68                 | 9.32   |
| MC4     | 1.80  | 2.38   | 24.36              | 13.53                         | 3.46              | 3.20                 | 9.72   |

**Table 2.** Results of XRD analysis.

| Minerals   | MJ1 | MJ2  | MJ3  | MJ4  | MC1 | MC2  | MC3 | MC4  |
|--|-----|------|------|------|-----|------|-----|------|
| Quartz (SiO <sub>2</sub> )   | 33  | 45.5 | 42   | 40.5 | 41  | 57   | 51  | 46   |
| Albite (Na <sub>2</sub> AlSi <sub>6</sub> O <sub>16</sub> )                    | 06  | 06   | 06,5 | 04   | 06  | 04   | 06  | 05   |
| Orthoclase(K <sub>2</sub> AlSi <sub>6</sub> O <sub>16</sub> )                  | -   | -    | -    | -    | -   | -    | -   | -    |
| Gypse (CaSO <sub>4</sub> 2H <sub>2</sub> O)                                    | -   | -    | -    | -    | -   | -    | -   | -    |
| Calcite (CaCO <sub>3</sub> )   | 30  | 24   | 32   | 28   | 44  | 24   | 18  | 25   |
| Dolomite (CaMg (CO <sub>3</sub> ) <sub>2</sub> )                               | -   | -    | -    | -    | -   | -    | -   | -    |
| Muscovite  | 15  | 05.5 | 02.5 | 05   | 05  | 03   | 06  | 06.5 |
| Kaolinite (Al <sub>2</sub> Si <sub>2</sub> O <sub>5</sub> (OH) <sub>4</sub> )  | 06  | -    | -    | -    | -   | -    | -   | -    |
| Hématite (FeO <sub>3</sub> )   | 03  | 03.5 | 02   | 04   | -   | 01.5 | 04  | 03.5 |
| Feldspaths K K <sub>2</sub> O 6SiO <sub>2</sub> Al <sub>2</sub> O <sub>3</sub> | 05  | 07   | 07.5 | 09   | 03  | 04   | 06  | 04   |
| Périclase MgO  | -   | -    | -    | -    | -   | -    | -   | -    |
| Clay materials   | -   | 08.5 | 06.5 | 07.5 | -   | -    | 07  | 09   |
| Others   | 02  | 01   | 01   | 02   | 01  | 01   | 02  | 01   |

highest value was found in the MJ4 sample, while in coating mortar, it varies from 1.68% to 5.60% and the highest value found was in sample MC2. The pH of all samples ranged between 9.20 and 9.91.

### Mineralogical composition

The results of the XRD mineralogical analysis reported in Table 2, revealed the presence of significant amounts of quartz and calcite. For jointing mortars, the amount of quartz varies between 33 to 45.5% for MJ1 and MJ2 and the amount of calcite varies between 24% for MJ2 and 32% for MJ3, while coating mortars have a quartz amount that varies between 41% for MC1 to 57% for MC2, and a calcite amount that varies between 18% for MC3 and 44% for MC1.

Furthermore, in all samples, the existence of Muscovite, Albite and Feldspars has been found, in amounts that vary between 2.5 to 15% for Muscovite, 4 to 6.5% for Albite and 3 to 9% for Feldspar. Other components, such as Hematite also have a presence in all samples but at

levels not exceeding 3.5%.

Apart from MJ1, MC1 and MC2 samples, all other samples contain clay materials in contents that range from 6.5% for MJ4 and 9% for MC4. On the contrary, kaolinite (6%) is present only in the MJ1 sample.

### Chemical composition

The chemical analysis results are provided in Table 3. These results show that the most important component of the various mortar samples is SiO<sub>2</sub> with rates ranging from 45.42% for MJ1 to 52.98% for MJ4 for all jointing mortar samples, while they range slightly higher for finishing mortars, with 49.00% for MC1 and 62.12% for MC2.

The CaO content is also important, however, in a lower percentage than the SiO<sub>2</sub> rates. They range between 13.25% to 17.27% for jointing mortars and 13.63 to 24.38% for coating mortar.

We have also noted significant levels of Al<sub>2</sub>O<sub>3</sub>, the content of which ranges from 7.29 to 10.96% for jointing

**Table 3.** Chemical compositions of the mortars Wt (%).

| Samples | Wt (%)           |                                |                                |       |      |                 |                  |                   |                               |                  |       | Hydraulic Index (HI) |
|---------|------------------|--------------------------------|--------------------------------|-------|------|-----------------|------------------|-------------------|-------------------------------|------------------|-------|----------------------|
|         | SiO <sub>2</sub> | Al <sub>2</sub> O <sub>3</sub> | Fe <sub>2</sub> O <sub>3</sub> | CaO   | MgO  | SO <sub>3</sub> | K <sub>2</sub> O | Na <sub>2</sub> O | P <sub>2</sub> O <sub>5</sub> | TiO <sub>2</sub> | LOI   |                      |
| MJ1     | 45.42            | 10.96                          | 4.31                           | 16.23 | 1.05 | 0.24            | 2.11             | 0.69              | 0.06                          | 0.62             | 16.29 | 3.51                 |
| MJ2     | 49.64            | 9.63                           | 2.86                           | 16.59 | 0.90 | 0.28            | 1.63             | 1.60              | 0.08                          | 0.32             | 19.48 | 3.55                 |
| MJ3     | 52.75            | 7.29                           | 3.39                           | 17.27 | 0.48 | 0.09            | 1.49             | 0.75              | 0.07                          | 0.34             | 16.08 | 3.57                 |
| MJ4     | 52.98            | 9.99                           | 3.27                           | 13.25 | 0.61 | 0.13            | 2.76             | 1.24              | 0.05                          | 0.41             | 15.30 | 4.77                 |
| MC1     | 49.00            | 4.05                           | 1.42                           | 24.38 | 0.30 | 0.13            | 0.81             | 0.67              | 0.05                          | 0.13             | 19.07 | 2.21                 |
| MC2     | 62.12            | 4.89                           | 1.76                           | 15.29 | 0.35 | 0.08            | 0.96             | 0.84              | 0.06                          | 0.17             | 13.49 | 4.39                 |
| MC3     | 51.71            | 10.54                          | 4.11                           | 18.47 | 1.37 | 0.15            | 1.81             | 0.90              | 0.12                          | 0.49             | 10.33 | 3.34                 |
| MC4     | 55.01            | 9.69                           | 4.66                           | 13.63 | 0.56 | 0.07            | 1.41             | 0.55              | 0.05                          | 0.47             | 13.91 | 4.88                 |

mortars and 4.05 to 10.54% for finishing mortars.

The highest values for the hydraulic index were recorded on the MJ4 sample, for jointing mortars and the MC4 sample for coating mortars. Furthermore, we note that the combination of oxides SiO<sub>2</sub>, Al<sub>2</sub>O<sub>3</sub> and Fe<sub>2</sub>O<sub>3</sub> for each of the two samples (MJ4 and MC4), are very significant (high).

## DISCUSSION

Of the set of samples, mortars exhibit a percentage of water absorption that ranges between 12.75 and 20.18%, corresponding to a porosity percentage between 21.59 and 31.89% for jointing mortar samples, and the percentage of water absorption ranges between 13.53 and 18.84%, to which corresponds a porosity percentage of between 24.36 and 28.84% for coating mortar. These results show that the percentage of porosity is proportional to the percentage of water absorption.

It is noted that the samples that have the largest concentrations of quartz and have an addition of broken brick, have the lowest absorption and porosity percentages, whereas those with a significant CaO content, have a higher absorption and porosity percentage.

In addition to our descriptions on the various samples, one can see that samples with the lowest percentage of porosity and absorption have a better state of conservation, as is the case of MJ4 (jointing mortar) and MC4 (coating mortar), both taken at Villa Mahieddine.

Insignificant contents of P<sub>2</sub>O<sub>5</sub> in all samples indicate the absence of organic material in the composition of the mortars. The pH of all samples is basic, according to the alkaline characteristics of minerals, which are found in mortars, such as calcite.

The chemical analysis shows the existence of a large amount of Silica (SiO<sub>2</sub>) in the composition of the various mortar samples taken from the city of Algiers; the origin of SiO<sub>2</sub> is predominantly sand. There are also significant amounts of lime, which means the existence of calcium carbonate in mortars however, the quantities, are

significantly lower than those of the Silica. To be noted, are also the significant amounts of aluminium oxide (Al<sub>2</sub>O<sub>3</sub>), while the remaining components Fe, Na and K only exist in moderate amounts. This means that broken brick can be found in the composition of mortars.

The XRD analysis of mortar shows the different minerals which composed mortars. The minerals with a highest contents are quartz and calcite (calcium carbonate), the samples of coating mortars have large amounts of quartz, which substantially exceed those found in jointing mortar samples.

The majority of samples, have higher quartz content than calcite content, with exception to the MJ1 and MC1 samples taken from the pillboxes (The Casemates), which have equivalent levels of quartz and calcite (33 and 30% for MJ1 and 41 and 44% for MC1).

To be noted, as regards all of the samples, the presence of smaller amounts of Albite and Muscovite, the source of which is likely to stem from additions of components such as baked brick and crushed or milled ceramic. The MJ1 sample, taken at the pillbox, shows that the mortar of that building contains Kaolinite, which is a clay mineral found in the manufacture of ceramics, while other samples, with exception to MC1 and MC2 samples, contain clay minerals, which confirm the presence of clay in the majority of mortars under study.

The hydraulic index (HI) is significant at the level of all mortar samples. The largest hydraulic index value is raised in the MJ4 and MC4 samples, taken from Villa Mahieddine. Both samples contain Muscovite (05 and 06.5%) and clay materials (07.5 and 09%). This finding allows us to argue that the number of additives, such as crushed bricks and ceramics, influences the hydraulic nature of mortars.

It should also be noted that there is a link between the chemical components of samples and their respective hydraulic indexes. Thus, samples containing a significant hydraulic index have significant levels of the following oxides: SiO<sub>2</sub>, Al<sub>2</sub>O<sub>3</sub> and Fe<sub>2</sub>O<sub>3</sub>. This allows us to say that the hydraulic nature of mortars also depends on the nature of the various additives (crushed or broken ceramics or bricks ...).

## Conclusion

The mineralogical and chemical compositions of different samples of mortars studied, allow us to identify the raw materials that were used in their manufacture. It shows us that the raw materials used in larger quantities were sand and lime in proportions that vary for jointing mortar, from one-part lime to one and a half (1, 5) parts to two (2) parts of sand (1 to 1, 5 - 2), in the case of samples taken from Casemates (pillboxes), the Casbah of Algiers and Villa Mahieddine. Whereas for these same buildings, coating mortars have a lime/ sand proportion that varies from one (1) part lime to two (2) to three (3) parts sand (1 to 2- 3).

Unlike that of the powder house, this has a lime/sand proportion of one-part lime to one-part sand (1 to 1). This proportion is the same for both the jointing mortar and finishing mortar.

The mineralogical analysis and calculation of hydraulic index have confirmed the hydraulic character of the different mortars studied, and have found that it is influenced by additives such as milled ceramics, crushed bricks and clay materials.

The composition of these mortars is done according to specific proportions of the various components: the most important component, as regards quantity, is quartz, followed by lime, which is used as a binder, and finally, although in smaller quantities, some additives, such as crushed bricks and clay materials.

The percentages of porosity and absorption are significant for most of the mortar samples. These two characteristics are influenced by the quantity of components of mortars. The mortars with a large amount of sand have a lower percentage of porosity and absorption, than the mortars with a smaller amount of sand.

All of these results have enabled us to see the similarities of the mortar components, their respective proportions, and their physical properties, despite the diversity of sites and buildings, which leads us to say that there was a common knowledge in the city of Algiers, which has endured for centuries, given that these buildings were built between the sixteenth and eighteenth centuries.

These results also confirm the composition of mortars that are reported in historical documents and archives of the Ottoman period in Algiers, however, we note that the correct amounts of binder and aggregates that have been mentioned in the works of S.Chergui, (one-part lime to two to three parts sand), are not the same in finishing mortar, while the jointing mortars studied, have been made according to other proportions (one-part lime to one-part and a half to two parts sand).

These physical and mineralogical results allow proposing better mortar preparations, used for restoration and repair the historical buildings. These new formulations of mortars are compatible and have lots of similarities with

the ancient mortars.

## Conflict of Interests

The authors have not declared any conflict of interest.

## REFERENCES

- Ait Ouakli S (2010). sous la direction du Pr. M.Hamiane et Pr. O. Boumghar, Elaboration d'un mortier de jointement et restitution 3D «cas du site de la villa Mahieddine», Mémoire de Magistère, Université M'hamedBougarra, DepartementGenie des matériaux, Boumerdes, 2010.
- Ashurst J (1983). Mortars, plasters and renders in conservation. Ecclesiastical Architects' and Surveyors' Association.
- Belaidi M (2011). sous la direction du Pr. M.Hamiane ,Etude des caractéristiques des mortiers historiques et proposition d'une formulation pour les mortiers de restauration,cas d'étude « Citadelle d'Alger » Magistère, Institut d'archéologie, Université Alger2, 2011.
- Binici H, Arocena A, Kapur S, Aksogan O, Kaplan H (2010). Investigation of the physico-chemical and microscopic properties of Ottoman mortars from Erzurum (Turkey), Constr. Build. Mater. 24(10):1995-2002.
- Boukhenouf A (2006). sous la direction du Pr. M.Hamiane. Caractérisation des mortiers archéologiques, le cas des sites historiques de Djemila et de la citadelle d'Alger, Mémoire de Magistère, Université M'hamed Bougarra, Departement Genie des matériaux, Boumerdes.
- Boynton RS (1980). Chemistry and Technology of Lime and Limestone, Wiley, New York.
- Büttner S, Prigent D (2007). Archéologie des liants de maçonnerie : entre traités et réalité, dans medieval Europe, Paris 2007, 4 eme congress international, d'archéologie medievale et moderne, 2007 (publication électronique), <http://medieval-europe-paris2007.univparis1.fr/S.B%C3%BCttner%20et%20al..pdf>.
- Chergui S (2007). Construire, gérer et conserver les mosquées en Al-Djazâ'ir ottomane, thèse de doctorat 3:834.
- Coutelas A (2003). Pétroarchéologie du mortier de chaux gallo-romain. Essai de reconstitution et d'interprétation des chaînes opératoires : du matériau au métier antique, Archives ouvertes HAL, 2003, [https://tel.archives-ouvertes.fr/tel-00528508/file/Coutelas\\_2003.pdf](https://tel.archives-ouvertes.fr/tel-00528508/file/Coutelas_2003.pdf)
- Foufa A (2010). Contribution to the discovery of earthquake - resistant techniques adopted in the large cities of the Maghreb (Algeria, Fez and Tunis) during the XVIII century " (2010) PhD Thesis, Algiers, Épau.
- Hamiane M, Ait ouakli S, Boumghar L, Zekagh W, Saidi A (2010). Design of jointing mortar compatible with masonry of the villa Mahiddine of the Ottoman Era, in RILEM proceeding PRO78."Historic Mortars and RILEM TC 203-RHM, Final workshop, HMC2010.
- Kurugöl S, Güleç A (2015). Physico-Chemical, Petrographical and Mechanical Properties of Mortars used in an Ancient Roman Basilica in Amasra/Turkey. Gazi Univ. J. Sci. 28(4):609-21.
- Lespès RA (1930). Etude Géographie et histoire urbaines. Librairie Felix Alcan, mai 1930, paris.
- Mallinowski R (1982). Durable préhistorique ancient mortars and concretes. Nordic Concrete Research in transportation research board. décembre P 22.
- Palazzo-Bertholon B (1998). Histoire, archéologie et archéométrie des mortiers et des enduits au Moyen Âge, Thèse de doctorat, Lyon II - Louis Lumière, Lyon.
- Rozert M (1930). Mémoires géologique sur les environs d'alger. journal de géologie 1930. Source gallica.bnf.fr/Bibliothèque nationale de France.
- Rota Rossi PD (1986). Mortars for restoration, basic requirements and quality control. Mater. Struct. 19:445.

*Full Length Research Paper*

## Development of a real time blood pressure, temperature measurement and reporting system for inpatients

J. O. Egwaile<sup>1\*</sup>, O. I. Omoifo<sup>2</sup>, O. O. Odia<sup>2</sup> and O. Okosun<sup>2</sup>

<sup>1</sup>Department of Electrical/Electronic Engineering, University of Benin, Benin City, Nigeria.

<sup>2</sup>Department of Computer Engineering, University of Benin, Benin City, Nigeria.

Received 8 June, 2016; Accepted 22 August, 2016

In this work, a real time blood pressure, temperature measurement and reporting system for inpatients was developed. The function of this system is to constantly measure the blood pressure and temperature of a patient and send the measured values to the medical doctor or other relevant care givers through wireless link. The system is built around the STM32F103C8 Microcontroller programmed in C language which performs the overall control action and interfaces with other peripherals like MPX5050GP and the DS18B20 which acts as primary sensors for blood pressure and temperature respectively. The health monitoring system was designed, constructed and tested. The results of blood pressure and body temperature measurements were compared with those of an OMRON blood pressure monitor and a clinical thermometer respectively. The deviations in measurements are on average  $\pm 4$  mmHg and  $\pm 0.17^\circ\text{C}$  for blood pressure and temperature respectively. This is considered satisfactory as the measurement error is found to be within tolerable limits.

**Key words:** Microcontroller, blood pressure sensor, temperature sensor, wireless link.

### INTRODUCTION

Patients are dying of high blood pressure or hypertension around the world especially in Africa because of lack of timely health care (WHO, 2013; Davies et al., 2014).

Hypertension is defined as increased blood pressure (BP) above 140 mmHg systolic and 90 mmHg diastolic when measured under standard conditions (Wagner et al., 2012; Pickering, 1996). The World Health Organization (WHO) considers hypertension to be a major chronic disease and a leading cause of death and disability in developing countries and it is estimated to affect a quarter of the world's adult population. (Lopez, 2006; Hansen et al., 2005). Blood pressure should be

therefore be kept within safe limits ( $<130$  mmHg systolic,  $<80$  mmHg diastolic (Chobanian et al., 2003).

Fever which results in high body temperature is also adding its death toll on patients (Garmel and Gus, 2012; Harry, 2015). Body temperature is one of the key parameter indicators of a person's health (Rush and Wetherall, 2003). For example, during the ebola disease outbreak in Nigeria, abnormal rise in a patient's body temperature was one of the suggestive signs that the patient may have contracted the dreaded virus. Body temperature can also be used to monitor the pain level of a patient after an operation (Jiann et al., 2007). High

\*Corresponding author. E-mail: joeranky@yahoo.com.

body temperatures could also be a symptom of other ailments. For children, high temperature could result in convulsion and eventual death, if not properly managed.

The normal temperature of the human body is approximately 37°C, with variations depending on the person's age and environment (Malhi et al., 2012).

Most patients are not well versed with manual treatment which doctors normally use for tracking blood pressure. So there must be some device which would help patients to keep track on their health by themselves and to enable doctors or paramedical staff to monitor patients' health remotely. There are various instruments available in the market to keep track on internal body changes. But there are many limitations regarding their maintenance due their heavy cost, size of instruments, and mobility of patients.

To overcome these limitations, a device used to keep track on blood pressure and body temperature of a patient should be easy to use, portable, light weighted, etc so that it gives freedom of mobility for the patient. The device can be carried everywhere to keep track on patient's health. This device would help to keep track of the blood pressure and the body temperature of a patient and check for any abnormalities which will be promptly reported. The blood pressure and temperature monitoring system developed in this work uses information technology to provide continuous blood pressure and temperature readings to a medical expert located either within or outside a defined measurement area. This notification would help caregivers to take appropriate action when necessary. This timely intervention could help to avert fatalities that could otherwise have resulted.

Quite a great deal of work has been done in the area of remote health monitoring. For example, Zhang et al. (2013) designed an electronic blood pressure monitoring system based on mobile telemedicine system. Their design included a zigbee wireless transmission module for sending measured blood pressure data in real time. Challenge with this design is that zigbee has low memory capacity thus limited patients data can only be transmitted and stored.

Obahiagbon and Odigie (2015) developed a framework for intelligent remote blood pressure monitoring and control system. Here, measurements are sent in form of electronic pulses from the wireless sensor to a mobile device equipped with Wireless Application Protocol (WAP). The challenge with this design is that the mobile sensor device must be equipped with WAP and signals must be transmitted through WAP gateways.

Cheng et al. (2015), developed a remote temperature monitoring device. Their device uses a patient and coordinator approach involving measurement, transmission, receipt and recording patient temperatures via WiFi wireless network. The challenge with this design is that the device can only monitor temperature which has to be transmitted through a WiFi network which is complex and has inherently high power consumption.

## METHODOLOGY

The sections that follows presents the features of the designed system, and the methods adopted for the design of each block that makes up the complete circuit.

### Main features of the designed system

The design is that of an electronic system which is able to perform a non-invasive measurement of the blood pressure based on the principle of oscillometry, thus limitations resulting from auscultatory measurement systems is avoided in this design. The system is designed in such a way that it measures the blood pressure (BP) and temperature simultaneously and transmits same in real time to a medical personal within a defined location or RF coverage. The system can be programmed to transmit the measurands once in every minute. Moreover the proposed system is able to evaluate both the systolic and diastolic blood pressure values, temperature values and by means of a microcontroller evaluate them, and send an alarm signal to medical personnel should the measured values be abnormal. Above all, the design is simple, cheap portable and has very low power consumption.

The developed system is divided into two parts – Hardware and Software. The hardware unit is further divided into two modules – Transmitter and Receiver. The transmitter module consists of a microcontroller, two 74HC573 integrated circuits, power supply, LCD, nRF24L01+ transceiver module, dc motor pump, buzzer, blood pressure and temperature sensors etc. The receiver module also consists of a microcontroller, two 74HC573 integrated circuits, power supply, LCD, buzzer, nRF24L01+ transceiver module etc.

### Transmitter module

The transmitter module interfaces with the primary sensing devices, signal conditional elements and then send the measured values of temperature and blood pressure to the receiver module via a wireless link. The block diagram of the transmitter module is presented in Figure 1 and the description/design of the transmitter module is subsequently presented.

### Body temperature sensor – DS18B20

The DS18B20 temperature sensor is a precision integrated-circuit temperature sensor, whose output voltage is linearly proportional to the Celsius (Centigrade) temperature. The DS18B20 thus has an advantage over linear temperature sensors calibrated in ° Kelvin, as the user is not required to subtract a large constant voltage from its output to obtain convenient Centigrade scaling. The DS18B20 operates from -55 to +125°C temperature range, with ±0.5 accuracy from -10 to +85°C (Dallas Semiconductor Data Sheet, 2000). Some features of DS18B20 are:

- i) Calibrated directly in ° Celsius (Centigrade)
- ii) Linear + 10.0 mV/°C scale factor
- iii) Suitable for remote applications
- iv) Low cost due to wafer-level trimming
- v) Operates from 3.0 to 5.5 Volts

### Blood pressure sensor – MPX5050GP

The MPX5050 series piezoresistive transducer is a monolithic silicon pressure sensor designed for a wide range of applications, particularly those employing a microcontroller or microprocessor with A/D inputs. This transducer combines advanced

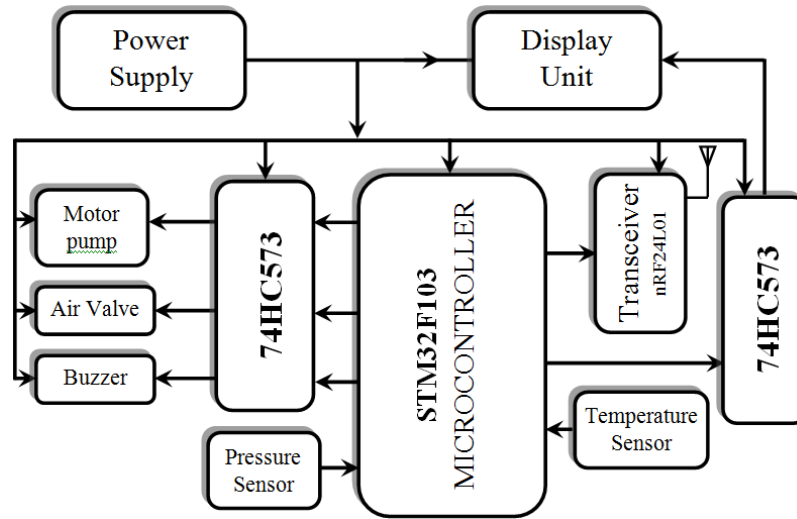

**Figure 1.** Block diagram of transmitter module.

micromachining techniques, thin film metallization, and bipolar processing to provide an accurate, high-level analog output signal that is proportional to the applied pressure (Freescale Semiconductor Data Sheet, 2000). The analog output of this sensor can be fed directly into a microcontroller with inbuilt ADC thus avoiding the need for an external analog filter. The following are some features of MPX5050GP:

- i) 2.5% Maximum Error Over 0° to 85°C
- ii) Patented Silicon Shear Stress Strain Gauge
- iii) Temperature Compensated Over -40° to +125°C
- iv) Ideally suited for microprocessor or microcontroller-based systems
- v) Sensitivity is 90 mV/kPa ( $\approx 12$  mV/mmHg)

The pressure sensor output pressure range is 0 to 50 kPa (0 to 7.25 psi) which is equivalent to 0.2 to 4.7V output range. Since the unit of blood pressure is usually in mmHg, there is need for conversion.

$$1 \text{ kPa} = 7.51164 \text{ mmHg}$$

$$50 \text{ kPa} = 375.582 \text{ mmHg}$$

Therefore, the pressure sensor output pressure range is 0 – 375.582 mmHg. This is particularly useful for this design as blood pressure measurements falls within this range.

The blood pressure measurement is based on the principle of oscillometry (Neil, 2001). In this method, the pressure sensor MPXV5050GP senses the pressure in the cuff attached to the patient's arm. The cuff is inflated and deflated by an electrically operated pump and valve. Initially the cuff is inflated in excess of the systolic arterial pressure, and then the cuff pressure reduces to below the diastolic pressure. Once the blood is present, but restricted, the cuff pressure will vary periodically in synchrony with the cyclic expansion and contraction of the brachial artery (Hartmann, 2016).

It has been shown that the pressure,  $P_m$ , at which the oscillations have the maximum amplitude,  $A_m$ , is the mean arterial pressure (MAP). Empirical and theoretical work has shown that the systolic and diastolic pressures,  $P_s$  and  $P_d$  respectively, occur when the amplitudes of oscillation,  $A_s$  and  $A_d$  respectively, are certain fractions of  $A_m$ :

- $P_s$  is the pressure above  $P_m$  at which  $A_s/A_m = 0.55$
- $P_d$  is the pressure below  $P_m$  at which  $A_d/A_m = 0.85$

Using this method, it is therefore possible to design a device for measuring Blood Pressure non-invasively.

Therefore, based on the oscillometric method, the values of systolic and diastolic pressures are computed from the raw data of cuff pressures sensed by the pressure sensor, using an algorithm.

#### **The nRF24L01 transceiver**

This RF module comprises of an nRF24L01+ transceiver. The nRF24L01+ is a single chip 2.4 GHz transceiver with an embedded baseband protocol engine (Enhanced ShockBurst), suitable for ultra low power wireless applications. The nRF24L01+ is designed for operation in the world wide ISM frequency band at 2.400 – 2.4835 GHz. It operates at a 1.9 to 3.6 V supply range (Nordic Semiconductor Data Sheet, 2008).

The proposed application is based on wireless networking. Therefore, nRF24L01+ transceiver is found to be suitable for this application. At least two nRF24L01+ modules are required, one for the transmitter and one for the receiver. The block diagram of the transceiver is presented in Figure 2.

The nRF24L01 transceiver has been programmed to transmit and receive signals of blood pressure and body temperature values after measurements from the transmitter unit to the receiver unit.

The integrated circuit 74HC573 is a buffer IC operating with a 5V power supply which is used to interface with the microcontroller STM32F103C8 which has an operating voltage range of 2.0V to 3.6V (Hartmann, 2016). A bypass capacitor is connected directly to the power source and to ground of each 74HC573 integrated circuit. The bypass capacitor helps to filter electrical noise out of the circuit. Datasheet recommends a 100 nF (0.1  $\mu$ F) capacitor to compensate for current ripples on the power supply (Lopez, 2006).

The entire transmitter module is built around the STM32F103C8 microcontroller programmed in C language. It performs control actions for the system that interfaces with other peripherals, that is, 74HC573 buffer IC (NPX Semiconductor Data Sheet, 2016), DC motor pump and solenoid valve for inflating and deflating the cuff respectively, IRF3205 MOSFET and 2N222 BJT transistor for switching the motor and power amplification respectively. The



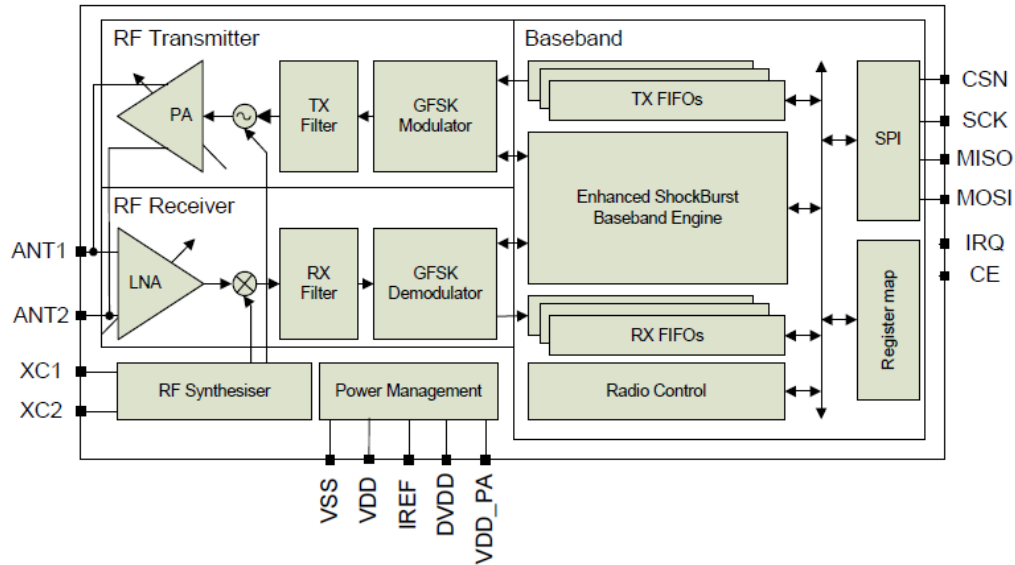

Figure 2. Block Diagram of nRF24L01 transceiver.

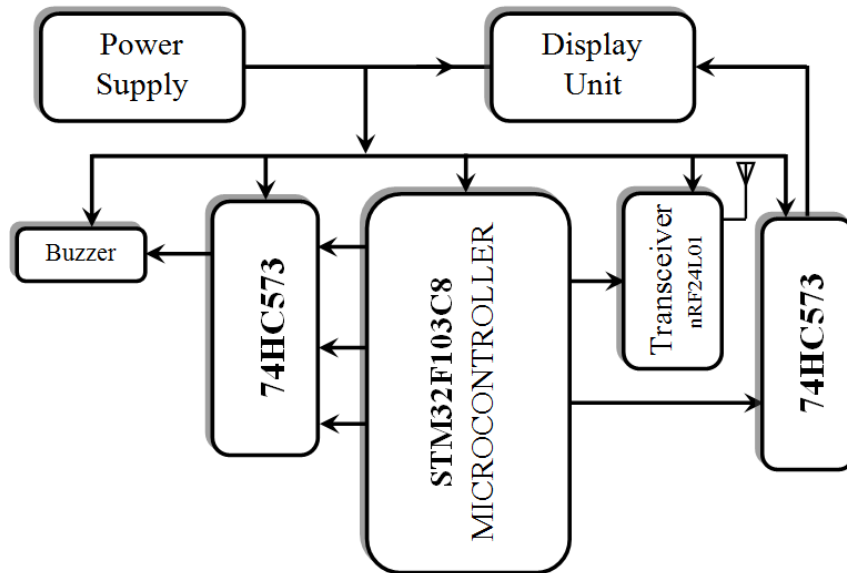

Figure 3. Block diagram of receiver.

values of base resistors of the 2N222 transistors can be any value within the typical recommended range of 1 – 10K.

STM32F103C8 is a 32-bit that provides a highly-flexible and cost-effective solution to many embedded control applications. It can operate with operating voltage levels from 2.0V to 3.6V (ST Microelectronics Semiconductor Data Sheet, 2007). The push buttons connected to the microcontrollers of both the transmitter and receiver units have pull resistors of 1k each between power supply of 3.3V and each of the push buttons. The values of these resistors can be any value within the typical recommended range of 1 – 10k. The pull resistors ensure a well-defined logical high state and prevents a high impedance state.

**The receiver module**

The function of the receiver unit (Figure 3) is to receive data from the air and then display the data as per the requirements on an LCD screen. The receiver can also receive data and transfer them into a PC with the help of a USB communication port for debugging of the circuit.

The microcontroller of the receiver has been programmed to monitor the values of body temperature and blood pressure received so as determine whether they are in range of predetermined limits, that is, lower limit and upper limit. This is achieved by comparing the incoming data of each channel with both limits. If the values are

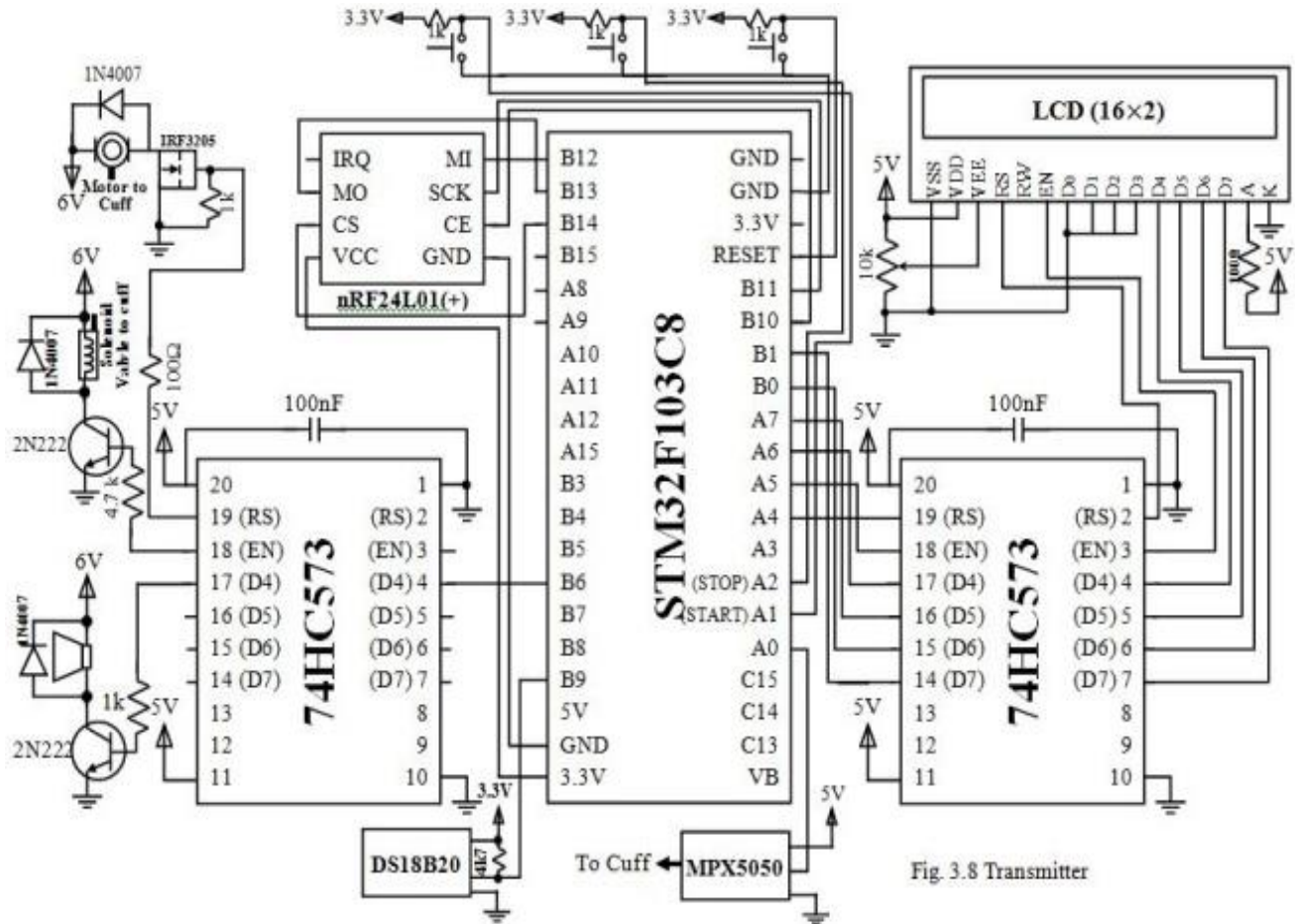

Figure 4. Transmitter circuit.

not within range, then the microcontroller will send a command to the buzzer to alert the doctor or any other medical staff of the abnormal readings for necessary action.

The buzzer has been programmed to come up when the systolic pressure,  $P_s$ , and the diastolic pressure,  $P_d$ , do not satisfy the conditions:  $90 \leq P_s \leq 140$  mmHg and  $60 \leq P_d \leq 90$  mmHg.

**CIRCUIT IMPLEMENTATION**

The designed circuit was replicated in a PCB using The EAGLE (Easily Applicable Graphical Layout Editor) software. The circuit diagram for the transmitter and receiver module is presented in Figures 4 and 5 respectively. The operation of the measurement system is presented in the flowchart of Figure 6.

**TEST RESULTS**

After the design and construction of the prototype, measurements of body temperature and blood pressure of five (5) volunteer patients were taken (one BP and one temperature measurement for each volunteer) and compared with measurements immediately taken from a conventional temperature and blood pressure

measurement kit for the same patients. The results of the measured body temperature, blood pressure, and error in both systolic and diastolic (for BP) and error in temperature measurement were tabulated and are shown in Tables 1 and 2.

**DISCUSSION**

As seen in Tables 1 and 2, the Real Time Blood Pressure, Temperature Measurement and Reporting System was able to measure the temperatures and blood pressure of the five (5) participants.

The temperature and blood pressure readings of the participants who wore the portable device were transmitted wirelessly to the main station (doctor's office) where they were monitored and evaluated.

From Table 1, it can be seen that the error in systolic values measured is approximately  $\pm 4$  mmHg. While the error in diastolic values, it is approximately  $\pm 5$  mmHg. Since the readings are not simultaneously taken, the time elapsed between the measurements by the prototype and the OMRON blood pressure monitor contributes to the

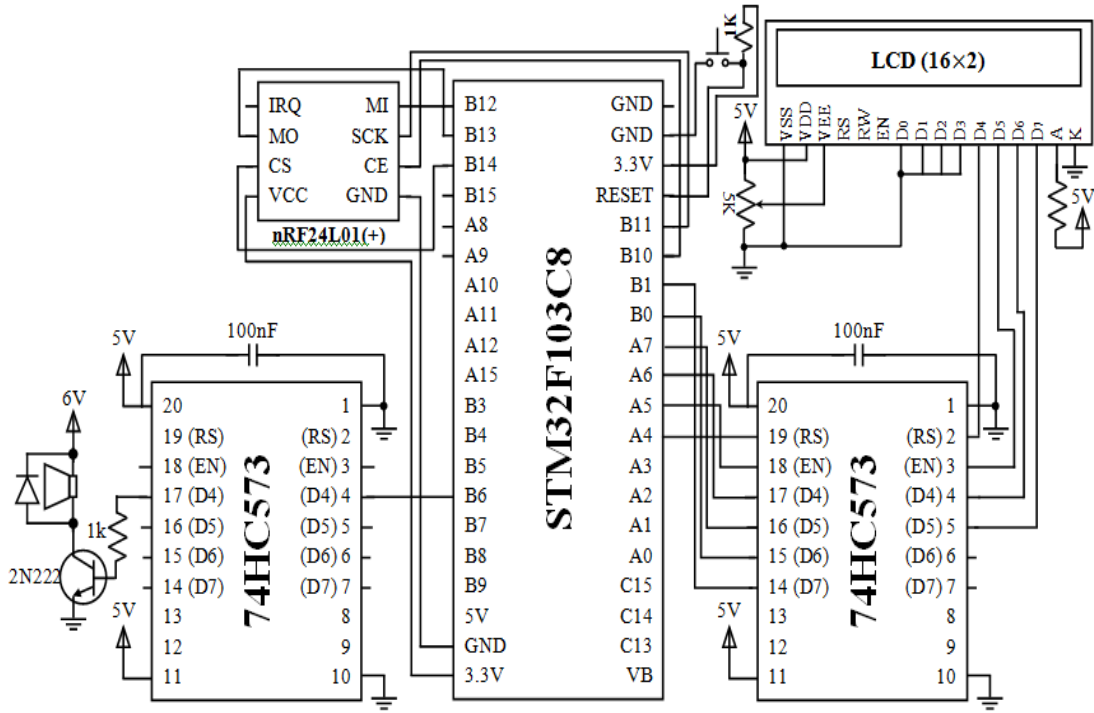

Figure 5. Receiver circuit.

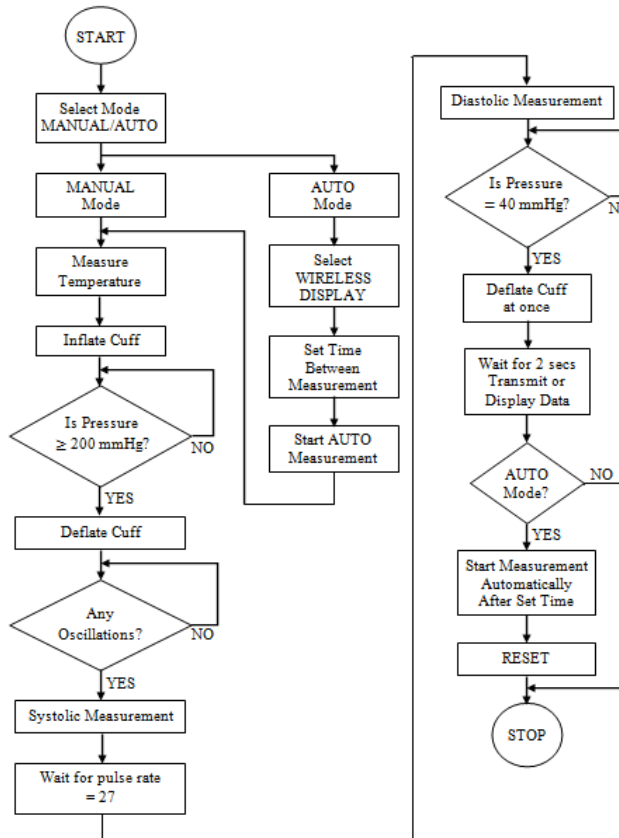

Figure 6. System flow chart.

**Table 1.** Test results for blood pressure measurement.

| S/N | Blood pressure (mmHg) |                              | Error |
|-----|-----------------------|------------------------------|-------|
|     | Measured by prototype | Measured by OMRON BP monitor |       |
| 1   | 122/86                | 125/83                       | 3/3   |
| 2   | 127/92                | 130/84                       | 3/8   |
| 3   | 110/83                | 116/76                       | 6/7   |
| 4   | 96/54                 | 100/57                       | 4/3   |
| 5   | 119/93                | 123/95                       | 4/2   |

**Table 2.** Test results for body temperature measurement.

| S/N | Body temperature (°C)            |                       | Error |
|-----|----------------------------------|-----------------------|-------|
|     | Measured by clinical thermometer | Measured by prototype |       |
| 1   | 33.7                             | 33.90                 | 0.20  |
| 2   | 36.8                             | 36.60                 | 0.20  |
| 3   | 31.5                             | 31.38                 | 0.12  |
| 4   | 34.5                             | 34.25                 | 0.25  |
| 5   | 33.5                             | 33.58                 | 0.08  |

deviation in measurement. Literature has it that because of the patient's position, his anxiety or expectations coupled with the unstable pulse rate of the human heart, no two blood pressure measurements taken one immediately after the other will give exactly the same results (Taram and Mike, 2012). Even when a conventional blood pressure monitor is used to measure a patient's blood pressure at two consecutive times, the measurements will not have exactly the same values.

The sensitivity of the temperature and the blood pressure sensors, and the performance of the blood pressure pumping motors all contribute to errors in measurement of the patient's body variations. The transmitter antenna power also limits the transmission range or distance of the measured values. The measurement errors are however within tolerable limits as they do not vary significantly for reading taken with conventional measurement kits.

On the average the error margin for the proposed prototype is  $\pm 0.17$  which is a tolerable deviation.

## Conclusion

The Automatic Wireless Patient Health Monitoring System for measurement of patients' temperature and blood pressure has been designed, built and tested using embedded technology. It is proposed to replace the existing manual systems with an integrated system. It uses temperature and blood pressure sensors to measure temperature and blood pressure respectively and automatically. The measured values are transmitted

and displayed on an LCD screen placed in the doctor's office or that of any of the paramedical staff in charge of monitoring patients' health. Any abnormalities in health conditions are informed via a display unit (LCD) and an alarm unit in the doctor's or paramedical staff's office. The hardware was implemented and it worked satisfactorily when tested.

## Conflict of Interests

The authors have not declared any conflict of interest.

## REFERENCES

- World Health Organization (2013). Nigerians Wake Up to High Blood Pressure. *Bull. World Health Organization* 91(4):237-312.
- Cheng SC, William A, Lok WW, Ehsan M (2015) Remote temperature monitoring device using a multiple patients-coordinator set design approach. *ROBOMECH J.* 2(4).
- Chobanian AV, Bakris GL, Black HR (2003). Seventh report of the joint national committee on prevention, detection, evaluation, and treatment of high blood pressure. *Hypertension* 42(6):1206-1252.
- Dallas Semiconductor Datasheet (2000). DS18B20 Programmable Resolution 1-Wire Digital Thermometer, [www.dalsemi.com](http://www.dalsemi.com), [Accessed: April 2, 2016].
- Davies AO, Catriona B, Adewale VA, Jacqueline YT, Felix AO (2014). An Estimate of the Prevalence of Hypertension in Nigeria. *J. Hypertens.* DOI: 10.1097/HJH.00000000000000413.
- Freescale Semiconductor Datasheet (2010). Integrated Silicon Pressure Sensor On-Chip Signal Conditioned, Temperature Compensated and Calibrated, MPX5050, [www.freescale.com](http://www.freescale.com). [Accessed: April 2, 2016].
- Garmel T, Gus M (2012). *An Introduction to Clinical Emergency Medicine*, (2<sup>nd</sup> ed.), Cambridge: Cambridge University Press P 375. ISBN 0521747767.
- Hansen NE, Haunsø S, Schaffalitzky de Muuckadell OB (2005).

- Hypertensio arterialis* Medicinsk kompendium, Nyt Nordisk Forlag Arnold Busck, Copenhagen, Denmark pp. 314-315.
- Harry HO (2015). *Fever: Its Biology, Evolution, and Function*. Princeton University Press, page 57. ISBN 9781400869831.
- Hartmann P (2016). "Oscillometric Measurement Devices," <http://tensoval.com/oscillometric-measurement-devices.php>. [Accessed: March 12, 2016]
- Jiann SS, Chun YD, Yeong RW, Wei ZS (2007). A novel fuzzy pain demand index derived from patient-controlled analgesia for postoperative pain. *IEEE Trans. Biomed. Eng.* 54(12):2123–2132
- Lopez AD (2006). Global and regional burden of disease and risk factors, 2001: systematic analysis of population health data. *Lancet.* 367(9524):1747-57.
- Malhi K, Mukhopadhyay SC, Schnepfer J, Haefke M, Ewald H (2012). A zigbee-based wearable physiological parameters monitoring system. *IEEE J. Sens.* 12(3):423-430.
- Neil T (2001). *Oscillometry*. Michael Mas pub. pp. 48-54.
- Nordic Semiconductor Datasheet (2008). "nRF24L01+ Single Chip 2.4GHz Transceiver," [www.nordicsemi.no](http://www.nordicsemi.no), accessed April 5, 2016.
- NPX Semiconductors Product Data Sheet (2016). "74HC573; 74HCT573 Octal D-type Transparent Latch. 3-State." <http://www.nxp.com>, accessed on April 6, 2016.
- Obahiagbon K, Odigie B (2015). A Framework for Intelligent Remote Blood Pressure Monitoring and Control System for Developing Countries. *J. Comput. Sci. Appl.* 3(1):11-17.
- Pickering T (1996). Recommendations for the use of home (self) and ambulatory blood pressure monitoring. *Am. J. Hypertens.* 9(1):1-11.
- Rush M, Wetherall A (2003). Temperature measurement: practice guidelines. *Paediatr. Nurs.* 15(9):25-28.
- ST Microelectronics Preliminary Data Sheet (2007). STM32F103x6, STM32F103x8 STM-32F103xB, [www.st.com](http://www.st.com). [Accessed: April 5, 2016].
- Wagner S, Toftegaard TS, Bertelsen O (2012). Challenges in Blood Pressure Self-Measurement. *Int. J. Telemedicine Appl.* ID 437350:1-8.
- Zhang JI, Liu Y, Wen J (2013). Design of electronic blood pressure monitoring system based on mobile telemedicine system. *Proc. Int. Conf. Complex Med. Eng.* pp. 145-149.



# International Journal of Physical Sciences

## Related Journals Published by Academic Journals

- *African Journal of Pure and Applied Chemistry*
- *Journal of Internet and Information Systems*
- *Journal of Geology and Mining Research*
- *Journal of Oceanography and Marine Science*
- *Journal of Environmental Chemistry and Ecotoxicology*
- *Journal of Petroleum Technology and Alternative Fuels*

**academicJournals**